

TOP VIEW

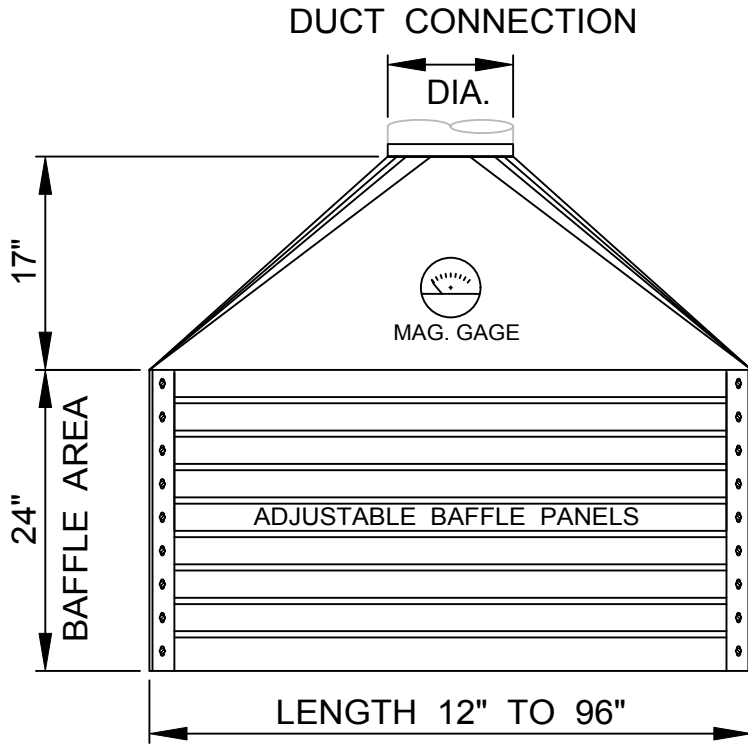

FRONT VIEW

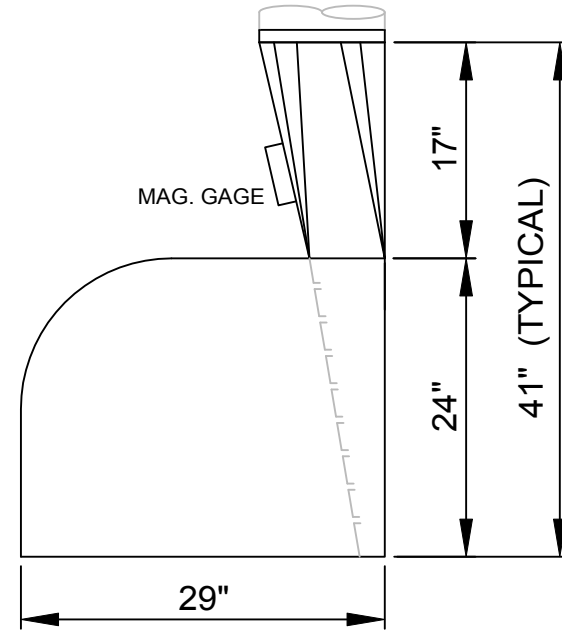

SIDE VIEW

**Standard Features:**

- \* EXTERIOR / INTERIOR: baked on epoxy powder coat finish. (Standard light gray, other colors available.)
- \* Exhaust Plenum: unit over 48" wide, 18 gauge, unit less than 48" wide 20 gauge.
- \* Exhaust Chamber: unit over 48" wide, 16 gauge, unit less than 48" wide 18 gauge.
- \* Side Wing Walls and Finished Back: 14 gauge.
- \* Plastic Safety U-Channel installed on Wing Walls
- \* Baffle Panels: 18 gauge or white chemical resistant hood liner.
- \* Visual Airflow Indicator: Magnehelic Gage.
- \* Capture velocity 18" in front of slots: *Typically 100 fpm*

**Options:**

- \* EXTERIOR / INTERIOR: Type 304 SS, 316 SS, or Galvanized steel,
- \* Balance Dampers or Blast Gates
- \* Rectangular Duct Connection
- \* Without wing walls.
- \* With movable center wing divider
- \* Wall mount with mounting tabs or free standing
- \* With Containment Pan

SLOT EXHAUSTERS

STANDARD UNIT



**NEWTECH**<sup>TM</sup>  
 THIS PRINT IS THE EXCLUSIVE PROPERTY OF ZEIGLER ENTERPRISES, INC.  
 NEWTECH<sup>TM</sup> is a trademark of ZEIGLER ENTERPRISES, INC.  
 Phone (866) 631-8324 FAX (989) 631-8362 E-MAIL: SALES@NEWTECHTM.COM

DATE: \_\_\_\_\_  
 SCALE: NA  
 DRAWN BY: WLZ  
 JOB No. \_\_\_\_\_  
 DWG. No. \_\_\_\_\_  
 SHEET 1 OF 1